

***SOCIETY for the PRESERVATION of
BEERS from the WOOD***
(founded 1963)

PINT in HAND

Number 120

November 2011



Harvey's Brewery, Lewes

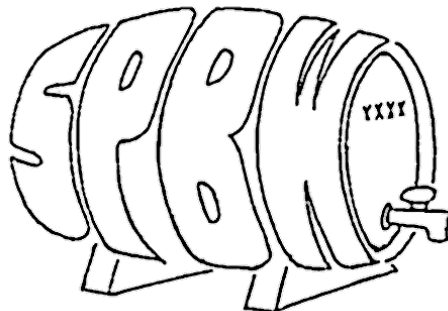

PINT in HAND

- ***Pint in Hand*** is published quarterly, in February, May, August and November. It is issued to all subscribing members and affiliated branches of SPBW.
- All members are invited to contribute articles for publication on beer-related subjects. Contributions for the February 2012 issue should reach the Editor by **25 January**.
- The Editor or the National Executive Committee of SPBW does not necessarily share opinions expressed in *Pint in Hand*.

© Copyright Society for the Preservation of Beers from the Wood

All photos by Roger Jacobson unless stated otherwise

Editorial address

Roger Jacobson, 2 Elizabeth House, St Leonards Street, London E3 3BX;
email editor@spbw.com; Tel 020 8980 9093

Membership Secretary

Roger West, Four Winds, 70 Chalfont Road, Seer Green, Beaconsfield,
Buckinghamshire HP9 2QP; email membership@spbw.com

Branch Liaison

Bill English, email beeel@myway.com; tel 07910 657423

Products

Dave Samuel; enquiries to Bill English, as above.

General Secretary

John Rooth, 20A Station Parade, Northolt Road, Harrow, Middlesex HA2
8HB; email john.rooth@gfk.com Tel: 07950 770921 [m]

National Chairman

Mike Hall, 15 Harvesters Close, Isleworth, Middlesex, TW7 7PP;
020888943901; email: mshall46@googlemail.com

Website: <http://www.spbw.com>.

On-line forum: <http://www.spbw.com/bb>

Anyone reading this that is not already a member of SPBW might like to know that annual membership costs only £5 (£6 non-UK). For information about SPBW together with a membership form, please send a stamped addressed envelope to the National Membership Secretary as above.

OPENING TIME

I'm going to the pub tonight. I will be drinking well-kept and superbly brewed traditional draught ales. I will be paying more than £3 a pint, possibly nearer £4 if I indulge in one of the stronger brews. Would I like to pay less for my beer? Well, of course. If the question was, would I prefer to spend less on a poorer quality product in less pleasant surroundings, that's a different matter entirely. It does seem that the beer drinker gets clobbered by repeated price hikes – and it's generally 10p a time rather than the odd penny or two we recall from budgets of an earlier era.

Let's face it, there's nowhere better to drink good beer than in a decent pub (some may prefer beer festivals but I don't). If there were no pubs there'd be no 'real ale'. There is really no better place for the consumption of any alcoholic beverage than a good pub – it's a controlled environment where anyone who has overindulged can be taken care of in the most appropriate manner. Unlike a park bench or bus shelter for instance.

But it's a sad fact of life that should you prefer to drink on a park bench or at home in front of the telly, you do so much cheaper than in the pub. I've just carried out an exhaustive survey in Tesco's across the road and found the following examples: Foster's 'lager' £14 for 14 x 440ml tins; 'Value Bitter' (2.1%!) 68p for 4 x 440ml tins; John Smith's Extra Smooth £10 for 18 x 440ml tins. Now of course, none of us in the palatial Pint in Hand editorial suite would besmirch our taste buds with such fluids. But obviously a lot of people do. My first three pints tonight will cost almost as much as that pack of John Smith's. They'll taste a whole lot better but many folk are not only less discerning but more price conscious.

There is a campaign going on for minimum pricing, meaning that such bargains I've mentioned will cost more, thus driving down the differential between supermarket and pub prices and therefore attracting more people to the pub. No less an individual than the Chairman of a major regional brewery in Suffolk is endorsing the campaigning (his 'IPA' is also on Tesco's shelves at way under pub prices). I hope the campaign succeeds; I want more people drinking quality beers in pubs. Getting the balance right is crucial. Let's not forget that there are people on low incomes, or the elderly and less mobile, who may be at a disadvantage if there is a major hike in supermarket prices. But it would be nice if they'd look farther along the shelf and take home something more palatable.

As we're approaching the Feast of Mammon, sometimes known as Christmas, let me offer very good wishes to all SPBW members and to all brewers and publicans who take pride in their profession. I hope 2012 is a very good year for you all.

Roger

Articles on beer/pub related issues are always welcome! Contributions to the Perfect Pub Page and Last Orders features in particular, as well as responses to my fevered ramblings above. If sending articles by email it would be very helpful if they are in Arial plain 12pt, single spacing with absolutely no formatting! Pictures should be in JPG format. Thanks.

NATIONAL EXECUTIVE COMMITTEE

The SPBW National Executive Committee holds its regular meetings on the second Monday of each month, starting at 7 pm or thereabouts, in the **Royal Oak**, Tabard Street, London SE1 4JU. If possible we use the upstairs room (it's quieter but further from the bar). These are strictly business meetings, but they are kept as brief as necessary. All members are welcome to attend, particularly representatives from branches.

ANNUAL GENERAL MEETING

The 2012 AGM of the SPBW's National Executive Committee will be held on **Monday 12 March**, probably at the Royal Oak. Full details will appear in the next issue of PiH, on our website and other electronic media. All SPBW members are invited to attend; AGMs are usually fairly brief and light-hearted and solid refreshments will be provided.

As ever we will welcome volunteers for an NEC post; please contact John Rooth if you are interested.

LONDON PUB OF THE YEAR

The winner for 2012 is the **Royal Oak** in Borough. This pub is surely well known to all discerning beer drinkers in London and beyond. Apart from being the only pub in London owned by Harvey's of Lewes, it is a thoroughly traditional establishment, free of distractions such as television and music. Conversation is king here, with top notch beer and food to help it along. You can usually expect to find 5 or 6 beers from the Harvey's range, from the tasty mild up to whatever the latest seasonal offering is, and there is also a 'guest' from a well-known regional brewery in Chiswick. Frank makes sure that the ales are served in top condition while John oversees the kitchen, which provides good hearty meals, well-cooked from quality produce.

This is the Royal Oak's third success in this competition. As you can see from the above items, the RO is much used by the SPBW in London and its cosy upstairs is a popular meeting place for a variety of other groups. Apart from Sunday evenings, the pub is open all day every day. The highly trendy Borough Market (with a selection of noted pubs) is just a short walk up the road but don't miss the Royal Oak if you're in the area.

The presentation to John and Frank will be on the evening of Monday 23 January and we hope to see a good attendance of SPBW members.

Royal Oak, 44 Tabard Street, London SE1 4JU

For the record, the runners up are the Harp, Covent Garden and Olde Mitre, Holborn.

NATIONAL WEEKEND 2011

20+ members have signed up for this year's event, which takes place soon after this issue is due out. York is the base and Roosters and York breweries are to be visited, along with the best pubs in the area. Hopefully someone will be taking copious notes so we can read the gory details next time round.

If you have any suggestions for somewhere to visit in 2012, please get in touch and let us know.

BEER & BUFFET

We've organised two of these popular events in recent months. The first, at the beginning of August, saw 19 members - including several from out of town - turned up at the Old Monk Exchange in Victoria. This basement pub just off Victoria Street was a new venue for us and proved to be a success. Beers were from Welton, Sambrook, Sharp and a major brewery in Suffolk. Handpumped cider was also available and it all helped to wash down a buffet that was ample if limited in choice. In late October we returned to Ye Olde Mitre, a genuinely historic pub hidden in an alleyway. About 20 of us braved the precipitous staircase to enjoy an excellent spread and jolly bonhomie in the upstairs function room. Downstairs Scotty and his troops were serving a decent range of ales including Harviestoun Bitter & Twisted and Rudgate Ruby Mild.

OUT AND ABOUT

Our usual team were present at the Wallington beer festival in mid-October. This was a successful venture in terms of product sales and recruitment. One or two decent pints were consumed as well.

Sadly, we're again unable to run a stall at the Pig's Ear festival in December – the venue is too small to contain us. However, don't let this deter you from going along – the beer fest is from 6 – 10 December at the Round Chapel, Powerscroft Road/Lower Clapton Road, London E5 0PU.

PINT IN HAND BY EMAIL

How would you like to receive PiH by email rather than by post? This would be of particular value to overseas members and would save the SPBW a few bob in terms of postage and envelopes. Beware that PiH is a substantial document (around 5MB) so you may need broadband if it's not to jam your inbox.

If you want to go for this, please email Roger West and Roger Jacobson (details on page 2) and we'll take it from there.

FROM THE ARCHIVES

30 years ago – September 1981 to be precise – saw the last ever issue of the Branch Newsletter (no 35); it would be replaced by the publication you are reading right now. The Newsletter reported on a visit to Gale's brewery by Special and Campden Hill branches; a traditional brewery and a traditional trip with the sample room being drunk dry! There was an introduction to Central London branch, then still in its relative infancy but with 8 brewery visits under its belt (all but one of those breweries now defunct!); and also a profile of Derek 'Catweazle' Legg who was then looking after the Society's products.

20 years ago I reported on my travels to the west coast of USA and the growing micro-brewery scene, and to West Yorkshire where Andy and the local SPBW branch took me to some of the best pubs in Leeds and beyond. Andy himself reported on a town rather closer to his own home, namely Ripon, where he managed to rush around 8 pubs in one evening. Some of the beers he drank are from breweries now defunct (Vaux, Mitchell, Whitbread), some fairly routine (Theakstons, John Smith), but with a few of the smaller brewers making an appearance (Old Mill, Marston Moor). Branch reports were fairly thin on the ground but I can report (for those of you who do not have PiH 40 to hand) that the former Suffolk branch won its annual conkers challenge against Dagworth & District Gentlemen's Cycling Society. Strangely, the paper used for the outside cover had four holes punched in it; presumably a job lot of cheap supplies.

10 years ago PiH had another of its 'mystery' covers, this time the Kings Arms in Henley being depicted. I'm sure I must have visited this Brakspear pub on my travels but there is no mention of it elsewhere in the issue. My travels, as reported, were on the canals in the West Midlands and beyond. Among the best pubs visited were the Station Buildings at Codsall, Haberdashers Arms at Knighton, and the Swan in Stone, all of which continue to be worth visiting. Andy's article was a random ramble from Huddersfield to Northern Ireland (not on the same night!). Andy devoted a fair chunk of his piece to a glowing review of the Station Tavern at Huddersfield, part of the station buildings. This is now known as the King's Head and continues to offer a wide range of ales. I recall, when I visited a few years back, that the pub sign depicted Jimi Hendrix, a king in his own way I guess.

The first winner of the London Pub of the Year award since its revival was the Dog & Bell in Deptford, which has won it thrice since. There was mention of a new branch starting up in Brighton, meeting at the Evening Star, then home to Dark Star brewery (and still owned by them). However, the branch never actually got off the ground. Just along the Sussex coast, Mayday branch was up and drinking, based at the First In Last Out brewpub in Hastings. The pub continues to brew its own but the pub spluttered to a halt a few years back.

A CROWN FOR THE CROWN

NORTHERN IRELAND BRANCH PUB OF THE YEAR 2011/12

The Crown is a prime example of a Victorian gin palace and a firm favourite of visitors, past and present. The Grade A listed building is from the 1840's and it was originally known as the Railway Tavern; it became the Crown about 1885. Tiled outside ground floor walls and tiled mosaic entrance lead to a lush interior of rich woodwork, coloured glass. A former owner was (apparently) not a lover of the British and had the crown tiled on the foyer so that people would be walking on it. The bar is long with three dividers and a black & white tiled floor. There are intimate snugs with bell pushes, mirrors and (surprisingly) doors, each guarded by a gryphon and a lion. It is often used as a location spot for films and plays.

The Crown, now part of the Nicholson group, has been in and out of the GBG; these days it serves Whitewater's Belfast Bitter and its own brew "Crown & Glory". George, the boss, is hoping to increase the range with rotating guest ales. Apart from its architecture, it should also be remembered for its basic pub food and seasonal oysters, normally washed down with liver crippling draughts of Guinness. Busy during the day, it comes into its own at night when the gas lamps play their wan light over the wide cross section of regulars and visitors from all parts of the globe. The upstairs lounge, once housing a roaring fire and memorabilia of the maritime history of the town, now goes under a theme name but still is worth a visit.

So, a worthy premise for an award! And on Wednesday, 28 September several branch members came along to a presentation of the SPBW NI POTY award. Along with George and his staff from the pub was owner of Whitewater Brewery, Bernard Sloan and the (in)famous mainstay of Belfast reporting, Jim McDowell. A really good and relaxing morning and thanks go to George for setting up the refreshments.



(l to r): George -Head Manager of the Crown, Mark - SPBW NI Chairman, Michael - Manager of the Crown, Bernard Sloan - Owner of Whitewater Brewing

Crown, 46 Great Victoria Street, Belfast BT2 7BA; www.crownbar.com

Mark Hutchison

BRANCHES IN ACTION

Camden Hill's September pub walk started off at the Bree Louise near Euston station which had the usual large range of beers and ciders both on tap and stillage. I had the Redemption IPA (excellent) from the pumps and a couple of ciders including a dark brown, very cloudy brew called Toffee Apple. On next to the Euston Tap in the old gatehouse outside the station precinct. Lots of cask real ales and continental beers at reasonable prices. Across the road to the Fullers Euston Flyer, thought to be a better bet than the Doric Arch, but beers a bit tired as is usually the case with Fullers nowadays. Finally the Betjeman Arms, on the first floor next to the large statue of the kissing couple in St Pancras station. Both Sharps beers, Red and Re-badged house beer (Cornish Coaster) were very good. Our November meeting was held in the Boardroom at the Betjeman, as the Cleveland Arms (our usual venue) is usually too noisy for comfort.

For our Halloween social we did an ambitious tour starting in Shepherds Bush at the Defector's Weld – Sambrook Wandle was good but the music was very loud; the Duchess of Cambridge in Goldhawk Road is a new sister pub to the Bree Louise – an excellent selection of beers and ciders and more comfortable than the Bree; the Duke of Sussex in Acton Green has recently been bought by Greene King so is likely to be ruined, but there were 3 good micro beers on; finally the Tabard adjacent to Turnham Green station with 6 handpumps. None of our group started the evening blood-stained or partially decapitated.

On 23 November we meet in the Salutation on King Street, Hammersmith, at 7.00, before going for a Vietnamese meal in Saigon, Saigon, also on King Street.

Common & Aldbrickham branch has recently selected the Blagrove Arms in Reading as pub of the year for 2011. It was visited by SPBW members following the recent trip to Bingham's Brewery, as reported in the last issue. We hope to present a certificate in the near future. Please contact John Dearing for further details.

We are also planning a fifth Peter Smith Memorial Pub Crawl and subject to confirmation this will be on Saturday 3 March and will probably take in some pubs in Greater London. Further details will be circulated in due course.

Kingston Branch has had a busy summer and we have lots planned for the coming months. Our Olympic Time Trial bike ride didn't set any course records apart from the number of beers consumed by the participants at the three chosen pubs en route (The Wheatsheaf, Esher Green, the Albert Arms, Esher and finally the Kings Arms, Hampton Court). I suspect Bradley Wiggins doesn't have much to worry about come selection time for the Great Britain squad unless it's based on beer drinking prowess rather than cycling ability. A very welcome addition to the local pub scene has been the Sussex Arms just off Twickenham Green, this genuine free house always has at least 10 beers on handpump all at £3 a pint all from local and (for Twickenham) unusual breweries and has already become a regular branch favourite

During October we've enjoyed a month long Oktoberfest at our Willoughby HQ with a different "theme" for each week of the festival such as "Old Favourites" and "Locales" The annual visit to the White Horse on Parsons Green for their "Old Ales Festival" is planned for Saturday 26th November

Our branch Christmas do will be at a new homebrew pub, The Botanist on Kew Green on Thursday 22 December. We have a meet the brewer evening there in November. All are welcome to our "meetings" held at the Willoughby Arms. (47 Willoughby Road Kingston, KY2 6LN on the first Wednesday of every month from 8.30pm) where social events are planned and local beer related issues discussed.

Norfolk Bears appear to have visited the Chappell beer festival in Suffolk and have planned trips to the Panther brewery – a new venture in Norfolk – and to various old haunts in London.

September saw the annual pilgrimage of **RACS** to Chappel Beer Fest at Wakes Colne Station yard. Always a good evening out though this year it was decidedly chilly! 1 October was a hot, sunny day trip to Ascot for racing and a beer festival on the racecourse. Much enjoyed and marked for a visit again next year.

Sadly a Quiz had to be cancelled for lack of support which has led, with one thing and another, to RACS taking stock of their position and having an online survey for members to try and point the way forward. If all goes well we have a Quiz lined up for November and a Christmas Awayday to Cambridge for shopping, beer tasting and anything else legal that can be done in Cambridge!

Wantz branch has moved its meeting place to the Old Fountain (just off City Road, near Old Street tube). The Pembury Tavern was getting too busy for a quiet meeting and the Monday night quiz was a bit disruptive (even though we won it once). The OF is convenient for all and offers a good range of beers so it's a highly suitable venue.

Our one outing in recent months was a return visit to Ciao Bella, a fine Italian restaurant in Lamb's Conduit Street, Bloomsbury. Our aperitifs were taken next door in the Lamb where the usual Youngs offerings were outnumbered by the guest ales, rather a sign of the times. Coming up in November is yet another visit to our favourite Thai place, Singburi in Leytonstone High Road, and a pub walk in Stratford including two pubs (one with in-house brewery) in the new and thoroughly ghastly Westfield shopping centre.

West Riding has enjoyed trips to Ribble Valley and Derby in recent months. The presentation for our Pub of the Season award to Guiseley Factory Workers Club went well with over 20 members attending the presentation. The club has won many CAMRA awards over the years and has recently become totally free of tie so even more opportunity for the range of real ales available to excel. This is the second time an award has gone to a club and not a pub the previous club was the Red Shed in Wakefield, many years ago and I am pleased to say the place is still going strong. The branch will hold its annual Christmas party at the Grove in Holbeck. Date should be either 28 or 29 December. We have to check with Santa first to see that he is not too busy.

MEET the BRANCHES

We have 17 affiliated branches and details of these are listed below. We always encourage members to join a local branch and get involved with its social activities. Most branches would appreciate new members so you can expect a warm welcome. Branches tend to be fairly informal, meetings being free of boring bureaucracy.

If you don't have a local branch, why not start one? Bill English, (Branch Liaison Officer, address on page 2), will be pleased to tell you what you need to know.

BMAD: Meetings held first Thursday of each month at the **Burnt Mill Snooker and Social Club** (CIU affiliated) in Harlow, Essex. Contact Tony Syrett (01279 423174)

CAMPDEN HILL: Meetings held first Monday of each month, possibly at the **Cleveland Arms**, 28 Chilworth Street, Paddington, London W2 6PT. Contact John Rooth (see page 2).

CENTRAL LONDON: Meetings held on the 18th of each month mostly in the form of pub evaluation walks - usually in central London. Contact Roger West (see page 2).

CHESAPEAKE BAY: Based in the area around Baltimore, Maryland USA - a great area for microbrews and brewpubs. Contact Ed James, email secretary@spbw.org. Website: www.spbw.org.

CHESHIRE REAL ALE PEOPLE: Are based mainly around the Crewe/Nantwich area. Informal meetings are held each Monday from 7.30 in the Borough Arms, Earle Street, Crewe (some beers £1.50 a pint), then to Hops, Prince Albert Street, Crewe – all real ales £2 a pint for Camra members. Contact Colin Donald 01270 623376 email colinsdonald@sky.com.

COATE: Meetings held third Friday of each month at the **New Inn**, Coate, near Devizes. Contact Eric Clark (ericclark@aol.com) or email coate@spbw.com.

COMMON & ALDBRICKHAM: Meetings usually held in Reading; contact John Dearing 0118 958 0377 or gpwild@btconnect.com to find out where and when.

CROYDON REAL ALE PRESERVATION SOCIETY: Meet on the first Tuesday of each month in **The Green Dragon**, High Street Croydon CR0 1NA, and also every subsequent Tuesday at a pub somewhere in, or easily reachable by public transport from, Croydon. Contact Pete McGill 07831 561296 (m) or John Smith 02071884844 (w).

FÝÇÝ: A social group formed by ex-pat SPBW stalwarts Peter Willett and Dave Brightwell. Contact Peter for more details: peterwillettuk@yahoo.com

IPSWICH: Contact Phil (01473 280822) or Iain (07707 465750) for details of meetings.

KINGSTON: Meetings held first Wednesday of each month in the **Willoughby Arms**, 47 Willoughby Road. Contact <http://spbwkingston.co.uk/diary> or email mike.lapworth@talk21.com

NORFOLK BEARS: Meetings held first Thursday of each month at 12.30 in the **Fat Cat**, 49 West End Street, Norwich. The landlord, Colin Keatley, regularly supplies three pins of Fat Cat (and other) beers from the wood. More details at: <http://www.spbw.com/norfolk/about.html>

NORTHERN IRELAND: Normally meet at the Bridge House (JDW), Belfast, on a Friday night after 8pm, at the pillar beside the handpumps. Occasionally the Tuesday Bell (JDW), Lisburn, after 8pm on a Saturday. Contact Mark Hutchinson for details of meetings and events:

marksalehousecom@hotmail.com

RACS: The Real Ale Club of Sawbridgeworth meets last Wednesday of each month at **The Gate**, London Road. Contact Jan Mead (01279 864398) or email meadspanner@ntlworld.com or the website www.racs.org.

SPECIAL: The branch holds annual, week-long gatherings around the inland waterways network. There are also unofficial visits to pubs of renown in London, Cumbria, Cheshire and Shropshire, or wherever we happen to be.

WANTZ: Meetings are held third Monday of the month at the **Old Fountain**, 3 Baldwin Street (off City Road), London EC1V 9NU, starting at around 7.30 pm. Contact Roger Jacobson (see page 2); also check out our website at www.wantz.co.uk

WEST RIDING: Meets (usually) on last Sunday morning in month in various pubs in and around Leeds. Brewery trips, day trips and crawls and other socials. Contact Graham Hewitt (0113 2624574; graham-hewitt@tiscali.co.uk) for further details.

WOOLWICH: Meetings held first Thursday of each month at 8.30 pm at the Prince Albert (Rose's), Hare Street, Woolwich. Usually four handpumped guest beers are available. Contact Bill Smith (020 8310 5907).

Are the details for your branch correct on these pages? If not please the Editor know before the deadline for the next issue; thanks!

SPBW ONLINE

The SPBW **Members Forum** is still going strong at www.spbw.com/bb. The Bulletin Board is intended as a way for members to exchange information. It's very easy to get involved with and, as with most things, the more the merrier. We are particularly keen to see representatives of branches acting as moderators to help keep their sections up to date.

The SPBW now has its own **Facebook** page (if that's the right technical term). If you're not familiar with this 'social networking' site, go to www.facebook.com – set yourself up with a password and put 'SPBW' in 'Search' and all will be revealed!

MADNESS ON THE EDGE OF TOWN

Andy's Roving Report

I've mentioned **Mr Foley's** in Leeds before in PiH but feel that the International IPA festival hosted there at the start of August makes it worthy of another article. I rolled up in the evening to find a packed out pub and was informed that it had been like that since about 4.00 in the afternoon. The quartet of bar staff were dashing about serving the hordes but one never has to wait long in this hostelry before the staff get around to you, even in the midst of a throng. I elbowed my way through the mob and managed to get a look at the beer menu; 6 cask beers from Buxton, Hardknott, Thornbridge, Roosters and Redwillow (that I can remember); 3 keg from Summer Wine, Brewdog and Magic Rock along with 12 bottled beers which included the likes of Dogfish Head, Victory, Stone and Odell's from the USA. There'd apparently been some enthusiasts queuing up outside at opening time to try the rather rare Dogfish Head 90 Minute IPA. Lest I forget, there was also a highly flavoursome tinned Hawaiian IPA called Big Swell from the Maui Brewery which contains seven different hops and, at 6.8%, makes you realise that our own (mainly vile) British canned beers could actually be pretty good.

I started on the Buxton Brewery's Axe Edge (6.8%) and it is excellent - too bad it is so strong, although next to some of the other IPA's it was of the lower end of the gravity scale! A few of the brewers were in situ and gave short speeches from the balcony through the kind of PA system normally associated with bingo callers. We even got a sample of an 11.3% black IPA from a nice lady rep from Brewdog. Mr Foley's didn't start to empty until about 10.00 and anyone who has seen the size of the place inside will realise just how many customers had been served. All in all an excellent night out; the beer was top rate, the company no ghastlier than usual and, best of all, no hangover or head-full-of-cotton-wool next day. There's always bottled IPA from the likes of Odell's and Brewdog available amongst the rather eclectic selection in the fridges and of course cask IPA turns up regularly amongst the guest beers; well worth calling in. See more about the pub on their Facebook page.

Mr Foley's Cask Ale House, 159 The Headrow, Leeds LS1 5RG; tel 0113 2429674.

The rather large **Richardson's Arms** in Oakenshaw stands next to the church of St Andrew's and is named after the Richardson family of Bierley Hall, who were once Lords of the Manor. I think I'm right in saying that this bit of Oakenshaw is in Kirklees, with another part being in Bradford. Built around 1857, it was also the venue for the local Court Leet, which was a court of record and reviewed trade practices; officials might include constables, ale tasters, flesh tasters and bread weighers. Another function was to try by jury and punish crimes committed within the jurisdiction. The last Court Leet was held at the Richardson's Arms on October 23rd, 1878.

Anyway back up to date; on the Monday night that myself and Hick rolled in here, there were 4 handpumps in use, dispensing Moorhouse's Black Cat mild and Blonde Witch, along with 2 from the Copper Dragon Brewery. We tried the

Moorhouse's beers and they were both excellent, the mild being absolutely first class. Presumably more of the handpumps go into action on a weekend. Unfortunately, the pub interior has been pretty much ripped out at some period. Looking straight towards the bar counter from the main bar area, there's a drop down TV screen to the left in a sort of nook which is also where the bands set up that perform here on Friday nights. Over to the right is the games area with the pool table as well as a dart board, beneath which is a small, rather old looking fireplace with a wooden surround. Upstairs there is a function room that holds about 70 people and has its own bar. This is a good pub and the locals should be glad the Richardson's Arms is still here; back in March 2010 there was an application to extend the building for change of use from a public house to a swimming pool! Thankfully that idea was killed off and we've got a pub that is worth calling in at.

Richardson's Arms, 684 Bradford Road, Oakenshaw, BD12 7EN; tel 01274 675722

Bang in the centre of York and one of the main attractions for tourists, Stonegate has a number of hostelrys situated inside some creakingly ancient buildings. ***The House Of Trembling Madness*** is not obvious from the street level though, being above a specialist beer and spirits shop called The Bottle. One walks into the shop and turns left up the stairs, emerging through the door at the top by the side of the bar counter. The premises were once called the "Beams Tearoom" and when you look up you can see why that name was chosen; now here's some woodwork that wasn't nailed on in the 1960s folks. Extremely old, (the owner reckons 12th century) these, with the arched ceiling above, make me think of a cruck barn - Cruck comes from the old Norse *Kraka* meaning 'hook' for those who don't check up on Wikipedia. Another inescapable bit of decor is the antique looking display of animal heads, ranging from a lion to a mole!

The HOTM covers no great acreage at all and was packed with drinkers and munchers on the Sunday night that I called in. You may be fortunate to be able to squeeze onto one of the wooden seats; there's even some 70's style barrel seating, the like of which is rarely seen these days. As for the beer, there was one handpump (selling Thornbridge's Chiron when I was there) along with 6 fonts and a selection of bottled beers including offerings from the marvellous Magic Rock Brewery of Huddersfield - try their Human Cannonball IPA if you get the chance.

The House Of Trembling Madness has already attracted an enthusiastic following it seems, which isn't bad when you consider that it opened only last year. The name is inspired by the beer Delirium Tremens and you can find this, along with an astounding range of British and foreign ales, in the shop below. Easiest way to find the HOTM is to walk up Stonegate towards the Minster, look for the Little Betty's cafe on your left and you'll see the shop just up from there. I think there is a sign outside on the pavement. Well worth looking for say I.

The House Of Trembling Madness; 48 Stonegate, York YO1 8AS; tel: 029 20391910.

I WISH THEY ALL COULD BE CALIFORNIA BEERS

When I first travelled to the USA, in the year that men first walked on the moon, it was easy to decide which beers to drink: Bud, Coors, Schlitz - or nothing. Craft ales were as common as water on the moon itself. Since those far-off days, the brewing industry has thankfully reinvented itself and on the west coast, hardly any city with over 100,000 people is without its brewpub. So in the late summer of 2011 five of us from Special Branch decided to break away from the comfort zone of the English canals (nice as they are) and set out on a three-week circuit of California and southern Oregon. The trip was planned meticulously so that we would visit a new town almost every night; hence I will describe just a few of the numerous watering holes that we visited. Our trip began and ended in San Francisco, although Lewis, who had joined us from Australia, continued south after we flew home. SF is many people's favourite American city and it's not hard to agree. The Golden Gate, Fishermen's Wharf, Chinatown, Telegraph Hill, the antique cable cars, plus an almost perfect climate; who would want more? It's easy to imagine Dirty Harry screeching round a corner at 100 mph ready to consign his fugitives to Alcatraz and ask questions afterwards.

There are several things to note about American bars. Most of them provide table service, which while adding to the cost will ensure that your glass is never empty. Indeed, if there is any downside it's that while most staff are very courteous, a few are over-enthusiastic and hover around like wasps on a jam jar. In most places the beers are served in US pints, which being smaller than Imperial pints, in alcohol terms make one US pint at 5% ABV equivalent to one Imperial at 4%. Always nice to know, except that some places use Imperial glasses! Another issue is that not all beer clips show their ABV, which surprises me a bit in a country that delights in risk aversion, although the staff can sometimes ask the head brewer at least to differentiate between "weak" and "strong". If after a few pints, your "not ash thinks ash you drunk I am" index is high, you know it's around 7%. Further damage can be reduced by the staff readily providing glasses of water, especially useful on a hot day. As for the bars, many of them have outgrown their sleazy reputation and most of the brewpubs, far from being the preserve of moth-eaten anoraks, are trendy with a lively student atmosphere (most of us were decades past our sell-by date but we might have passed for university lecturers). To satisfy one's every taste in sport, many bars are lined with a battery of TVs and at some places, Monday night is football night and they serve beer at \$3 a pint for the duration of the game.

Our first port of call in San Francisco was the ***Thirsty Bear***, a busy, prosperous place in the commercial centre of the city. While taking a break from the excellent Polar Bear Pilsner (5.7%), I went shopping and in my absence, the others were treated to a free beer because the head brewer noticed them reading *The Good Beer Guide to the West Coast*! Talk about

being in the wrong place at the right time. The beer in question was a cask-conditioned stout flavoured with camomile – most unusual. Continuing to the **21st Amendment** (named after the Act which ended Prohibition in 1933) - with an impressive choice of craft beers - South Park Blonde (refreshing, 5.0%), 5-South American Pale Ale (5.5%, not from Peru or Brazil but named after Interstate 5 which runs the length of California) and Brew Free or Die IPA (7.0%).



Outside the Thirsty Bear; inside the 21st Amendment

California Highway 1 skirts the coastline, which is one of the most beautiful in the world with numerous wild seashores bordered by dense forests. Very winding, it's best not to be attempted with a hangover - easier said than done! The weather is often cool and misty, but as we swung inland and up into Oregon, the clouds were burnt away by a powerful sun which sometimes pushed the temperatures into three figures F. Klamath Falls is a quiet town and like so many in these parts, has a history of logging. The **Creamery Brewpub & Grill**, with a sign of a smiling cow above the entrance, is the 'tap' for the Klamath Basin Brewery. Near the town centre, it's a friendly, spacious place. For me, the best was Pelican Butte Amber Ale, a citrus-tasting 5.2%, but the Bare Island Blonde, a refreshing 4.3%, came close. Like some other brewpubs, they tended to close early although the hours could be elastic. We were on last orders when the owner and brewer came round with a cameraman who filmed us singing the praises of American beers, fuelled by free samples. One day a clip may be shown on their website and we will all become film stars. I celebrated by buying a T-shirt of their Butt Crack Brown (crazy name, brilliant beer and it weighs in at a nutty 5.5%).

Heading south-east along the scorching Highway 99, we arrived a couple of days later at the pleasant but unremarkable town of Chico. The **Sierra Nevada Taproom**, however, is anything but ordinary, and too big to be considered "micro" any more. Their beers travel from sea to shining sea and with reason. The ordinary Pale Ale at 5.6% is their flagship ale, but they do a fine Porter, a rich, smoky 5.6% and three other regulars, plus around four seasonal ales. The staff here were second to none. Once again we let closing time catch up with us but the one remaining staff member, Corina, agreed willingly to make several calls to arrange for a van to take the five of us home.

Santa Cruz is a pleasant coastal town lying around 70 miles south of San Francisco. One rule to know for another time: if a big sporting event like the Big Fight is on, arrive at the bar early and expect to pay \$5 to “gerrin”. The **Seabright Brewery** was as good as anywhere on the trip, with impeccable service to cope with the capacity crowd. The golden Pelican Pale (5%) and the creamy Stout (5.8%) stood out. And before you ask, Mayweather survived a foul hit to beat Ortiz in the third round, so the bar cleared early and we finally had it almost to ourselves.



James and Roger with California girls



Magnolia

Back in San Francisco for the last day, we had time for a few at the **Magnolia Brewery**. It's one of the few that's set in what looks like an original bar, which might have been a rebuild after the earthquake of 1906. Sam Spade was here - maybe. The beers had some enticing names like Blue Bell Bitter and Sara's Ruby Mild and a few were cask-conditioned, but their ABV escapes me. Perhaps I was a bit tripped out; after all, the Magnolia does lie in the heart of Haight-Ashbury. The Brewer is indeed a Grateful Dead fan and Jerry Garcia & co had a house just 6 blocks down the road in their early days. What a long strange trip it had been and what a good place to end up at.

Just for the record, on the trip we did manage to visit a winery, the industrial-scale Robert Mondavi estate at Woodbridge in the central San Joaquin valley. Their wines can be found at Waitrose and the Shiraz is recommended!

James Collenette

SPREADING THE WORD

We regularly produce a publicity leaflet for SPBW incorporating a membership application form. Some of you may even have joined us having picked one up! We put these leaflets in friendly and obliging pubs but we would like to spread them as wide as we can, especially outside the London area. If you can help us with this, please let Roger Jacobson (details page 2) know and a bundle of leaflets will be sent. Thanks to those of you who have already helped in this way.

LANCS FOR THE MEMORY

A party of 30 from West Riding branch took to the wilds of Lancashire and a visit of attractive villages that surround the market town of Clitheroe and the once industrial mill town of Great Harwood. First stop, the village of Pendleton, bisected by a hurrying stream. **The Swan with Two Necks**, the West Pennines Region Pub of the Year, was a traditional cosy two roomed pub with beamed ceiling and open fire and large collection of ceramic teapots in the lounge, plus a small taproom to the rear with big screen TV. 5 beers: Hornbeam Mary Rose, Marble Pint and Dobber, Copper Dragon Golden Pippin and Castle Rock Black Gold.

Next to Clitheroe. From a choice of 8 or 10 pubs, I tried just two. **The New Inn** had 11 beers to choose from including Cross Bay Nightfall and Prospect Ginger Slinger, which were very good. The pub had four separate rooms leading from a central corridor and bar, (each splendid in their own right.) The bar had stained glass panels and the entry lobby had a fine tiled floor. The rooms could have been from an Edwardian drama. The second pub was the **Horseshoe Inn**. This two roomed pub had a large open lounge, with bare boards, wood tables and leather bench seats, 3 big screen TVs and dartboard for the sporty types. The beers included Bowland Sawley Tempted and Three B's Stokers Slake and Bee Blonde.



Dodging the worst of the weather we made for Waddington, avoiding a low bridge which looked a bit tricky for the coach. There are 3 pubs in the village but most concentrated on **Lower Buck**, a multi-roomed country house hotel with clean, modern décor, rustic furniture and flagged floors in main bar area and carpeted side rooms. There was a welcoming roaring open fire. There were two Moorhouses beers, Premium and Old, and Taylors Landlord.

From here it was down to the **Waddington Arms**, a substantial stone residential inn, open-planned with large stone fireplaces and solid wooden furniture. There was a massive stone fireplace in the left-hand room with wood burning stove and huge supply of wood. The three beers were Burton Bridge Golden Delicious, Tirril 1823 and Grays bitter.

A short drive through narrow, winding country lanes took us over the swollen, turbulent waters of the river Ribble and to the hamlet of Great Mitton. Our first pub was the whitewashed **Aspinall Arms** sitting by the Ribble. Beers from

Barnsley, Three B's and Tirril were on the bar. The pub had a spacious stone walled open lounge with chunky furniture and benches and two separate well-appointed dining rooms. For me the highlight of the inn was the gents toilets! These were totally painted with the most elaborate scenes which could be of Tolkein's Hobbitland. (not to be missed.) Outside was a rambling, grassy beer garden.



Aspinall Arms



Dog Inn

A short walk up the road brought us to **Mitton Hall**, a beautiful hotel of Baronial stately homes proportions, set in acres of landscaped gardens. Pure opulence, class, grandeur etc. Superlatives fail me. On the beer front, just one - Bowland Hen Harrier, not cheap but worth it for the ambience.

On then to Whalley, another picturesque village, this one backed by a high hill. There are four pubs in a clump on a mini-roundabout on King Street. The **Dog Inn** had a large, low-ceilinged, sloping lounge with upright piano and a games room with pool table. There was a small beer garden to the rear. 6 beers here included brews from Beartown, Thwaites, Moorhouses and Bowland. This is a one-roomed, modern and comfortable town pub. Note the large interesting painting of nobility above the open fire by the bar.

Our final stop was Great Harwood and the **Victoria**, which we found after meandering our way through vast tracts of Victorian terrace houses. This is a classic heritage pub, Grade 2 listed, thankfully, and so cannot be touched. Five separate rooms, all with individual characteristics, radiate from a central corridor and island bar. The whole of the corridor is tiled with unique light green and cream ceramic tiles from floor to ceiling. The bar itself is wood panelled with etched glass panes. The tiles also stretch up the open staircase to where you can find a teddy bear in a wicker chair. At the rear is a decked area and huge beer garden. There are extensive views of open country beyond to the rear. A range of 8 beers including Hornbeam Vibe, Pennine Sunshine, Barn gates Tag Lag, and Phoenix Pale Moonlight. This pub was a fitting end to what had been a day of a goodly range of beers and verdant Lancashire scenery.

Rick Lamb (who took the pictures)

EMAIL TO THE EDITOR

Roger,

I was interested by your reminiscences (PiH) 119 of times not-so-long ago. It brought to mind a period of about six months during which I worked in a pub in Birmingham. This was mid 60's, and the pub was an Ansell's house. We sold draught bitter at (as I recall) at prices between 1s 9d (9p), and 2s 1d (10p) per pint, depending on whether it was sold in the Public Bar, or one of the three lounges. Double Diamond attracted a surcharge of between 1p and 2p, presumably to pay for all that gas.

Mild was about 2p cheaper than bitter. Also, the slop trays were emptied into an open bucket. The bucket contained a mix of bitter, mild, lager, and lemonade, and it was hung next to the mild barrel in the cellar. For every half pint of mild dispensed, a teaspoonful of the mix was taken from the bucket straight to the glass. Ah, those pre- Health & Safety days!

Last week I paid £3.20 for a pint of bitter. And we complain about the cost of petrol! At the same time that I was working at the pub' I was getting 4 gallons of petrol for £1.00.

Regards,

Keith Burton (ex-member of the De Montfort and St. George branches)

EMAIL ADDRESSES

If you want to receive up to the minute news about SPBW events, you can get this information in the comfort of your own PC monitor. Send your email address to John Rooth and he will add you to his circulation list. We promise that your email details will only be used for the transmission of SPBW material.

Also, when events and news are published on the website you can be notified direct to your email by signing up for a FREE notification service on the news page. Go to: <http://spbw.com/news.html> and go to the 'Monitor changes' box in the bottom left corner.

PINTS IN PUBS

We have several publicans among our membership. If you are such a person and you are organising a beer festival, or any other special event in your pub, why not let us know? We can advertise the event in these pages and hopefully encourage our members to get along.

Some back issues of ***Pint in Hand*** are available:- numbers 46; 49; 86-119. These can be obtained from the Editor (address on page 2) in return for 12 second class stamps to cover postage for the full set. If you don't want the whole lot, send enough stamps you think may cover costs.

Most issues from 90 onwards can now be found on the SPBW website, in PDF format.

SPBW PRODUCTS

T-shirts

(woven motif on white L, XL/yellow L, XL/black L, XL, red L, XL) £9.00

Sweatshirts

(Woven motif on royal blue/burgundy/jade, XL only) £15.00

Polo Shirts

(woven motif on royal blue L, XL/burgundy L, XL/jade L, XL) £13.00

Fleeces

(Navy, royal blue, bottle green or black, L, XL, XXL) £21.00

Ties (contact Bill English for details)

Hats

*(Acrylic knitted, woven logo on light blue, black red, burgundy;
one size only)* £5.00

Enamel Badges

(gold motif on black rectangle) £4.00

Bottle openers and key rings with cask motif. £1.00

You can admire our product range on the SPBW website!

- **Please add £3.00 per order to cover postage and packing; if only ordering badges, bottle openers or key rings add only £1.00**
- **Please send your orders to Bill English** (see page 2)
- **Please make cheques payable to SPBW** and include a telephone number or email address with your order. Allow up to 28 days for delivery.



The Blaggrave Arms, Reading (see page 8)